

CMS



CU

Centrifugal pumps to be coupled to the power takeoff of the tractors normalized at 540 or 100 rpm. Hydraulic unit single stage (series CU) and double stage (series CMS)

Application fields and use limit:
Irrigation service by tractor or lifting water by different motive powers, such tank trucks. According to the materials normally used in the production, the pumps are suitable for lifting soft water which is chemically and mechanically not aggressive.
Max. water temperature: 80° C
Max. water hardness: 40 g/m3.

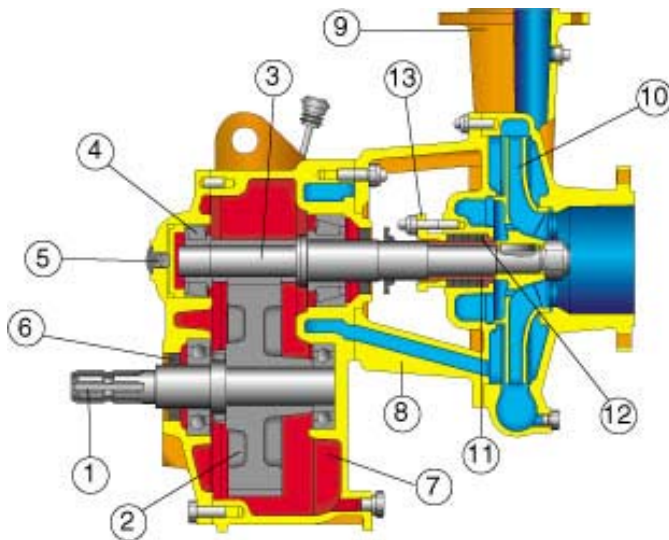

- Power takeoff
- 2 Driving crown gear (cemented and hardened Ni-Cr alloy steel)
 - 3 Pump pinion shaft (cemented and hardened Ni-Cr alloy steel)
 - 4 Bearing
 - 5 Bearing register
 - 6 Oil retaining ring
 - 7 Over gear-box
 - 8 Spacer
 - 9 Delivery body (fine-grained gray cast iron)
 - 10 Impeller (fine-grained gray cast iron or bronze on demand)
 - 11 Shaft bushing
 - 12 Packing (mechanical seal on demand)
 - 13 Packing gland